

TECH BRIEF

CPC5565

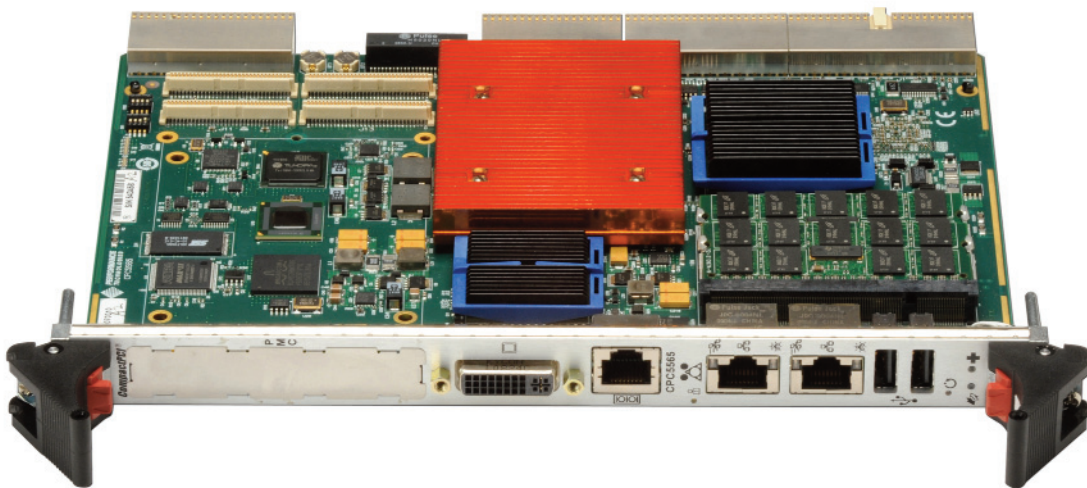

Intel® Core™ 2 Duo
Single Board Computer



www.pt.com

Introduction	3
Features	4
Processor	6
Chipset	7
CompactPCI® Bus Interface	8
Intelligent Platform Management Controller	8
Memory	9
Universal Serial Bus (USB)	9
AMD/ATI Radeon™ E2400 Video Processor	9
Video Features	10
SMARTSHADER 4.0 - Advanced Shader Technology	10
SMOOTHVISION 2.0 - Flexible Anti-Aliasing and Anisotropic Filtering	10
Avivo™ Display Support - Two Fully Functional Displays	10
Video Acceleration	11
Serial I/O	11
Ethernet Interface	11
SATA Interface	12
Rear Transition Module (Optional)	12
PTMC Interface (Build Option)	12
Drone Mode	13
Real-Time Clock, CMOS RAM and Battery	13
Reset	14
Two-Stage Watchdog Timer	14
LED Indicators	15
Rear-Panel I/O	15
Software	16
BIOS	16
Operating Systems Supported	16
Configuration Options	17
Thermal Design for Embedded Applications	17
Technical Specifications	19
About PT	20

PT, the recently rebranded Performance Technologies, designs, manufactures, and distributes a wide range of high performance blades, platforms, and a Carrier Grade Linux® Distribution (NexusWare®) that support the company's IPnexus® Application-Ready Systems.

This TECH BRIEF is an encapsulated summary of the technical functions of PT's latest Single Board Computer, the CPC5565. This high performance blade can be utilized in existing CompactPCI systems as an upgrade to a system controller or replacement component in 2.16 peer-to-peer computing platform. The CPC5565 also lies at the heart of every PT IPnexus CompactPCI Application-Ready System.

As command and control systems become more integrated and networked, having a robust communication infrastructure to provide the user community with the ability to collect and distribute information, while storing data for later analysis, is crucial to completing the assigned mission. Advances in IP-based networking, broadly used in civilian networks, can now be re-tasked to yield resilient, dependable systems that can survive unit damage and link failures.

The CPC5565 is a CompactPCI 64-bit, single-slot, single board computer, featuring the Intel® Core™2 Duo 2.2 GHz processor, designed for high-performance embedded applications. The board incorporates the Intel 3100 integrated northbridge/southbridge chipset, supporting an 800 MHz front-side bus interface and a 400 MHz 64-bit PC2-3200 DDR2 memory interface. It supports up to a total of 8 GB of DDR2 SDRAM with ECC in two 200-pin SO-RDIMM sockets.

The CPC5565 includes support for high-performance video and audio, featuring the Advanced Micro Devices (AMD)/ATI Radeon™ E2400 video processor. With support for up to six Serial Advanced Technology Attachment (SATA) hard disk drive (HDD) interfaces, the CPC5565 offers flexible combinations of storage solutions. The CPC5565 is designed to deliver exceptional 2D, 3D, and multimedia graphics performance for embedded systems that may require video/audio, hard disk/solid state storage, and low power consumption.

The CPC5565 features:

- ◆ Single Slot 6U compute blade
- ◆ 2.2 GHz dual core Intel® Core™2 Duo processor (T7500)
 - Intel 64 architecture
 - Supports Intel Architecture with Dynamic Execution
 - PC2-3200 DDR2 400 MHz memory controller interface
 - 32 KB Level 1 instruction cache (per core)
 - 32 KB Level 1 data cache (per core)
 - 4 MB Level 2 shared cache with Advanced Transfer Cache Architecture
 - 800 MHz, Source-Synchronous front-side bus
 - Intel Virtualization Technology
 - Execute Disable Bit support for enhanced security
- ◆ Supports up to 8 GB of PC2-3200 DDR2 SDRAM with ECC in two 200-pin SO-RDIMM sockets
- ◆ CompactPCI® Hot Swap Specification, PICMG 2.1, R 2.0 compliant
- ◆ CompactPCI PTMC Specification, PICMG 2.15 R1 compliant
- ◆ CompactPCI Packet Switched Backplane Specification, PICMG 2.16, R 1.0 compliant
- ◆ CompactPCI System Management Specification, PICMG 2.9, R 1.0 compliant
- ◆ IPMI v1.5 Specification compliant
- ◆ System management bus
- ◆ Intel 3100 Chipset
- ◆ Dual 10/100/1000 Mb/s Ethernet links are available on the front panel via RJ45 connectors
- ◆ AMD/ATI Radeon™ E2400 Video Processor
 - Internal 128 MB GDDR3 memory
 - High-performance 2D, 3D, and multimedia graphics
 - QXGA resolution up to 2048 x 1536
 - HDMI output for 480p, 720p, and 1080i
 - 32 bits per pixel
 - DirectX 10 and OpenGL 2.0 support
 - Video acceleration
 - Advanced de-interlacing algorithms
 - Programmable, independent gamma control for video overlay
 - SMARTSHADER™ 4.0
 - SMOOTHVISION™ 2.0
 - Dual-display mode
 - Integrated HD audio codec supports PCM and Dolby® Digital 5.1 audio formats

Features

- ◆ Support for one PMC or one SATA drive
- ◆ Up to 6 SATA interfaces
- ◆ PT's Embedded BIOS (AMI core) stored in local flash memory
- ◆ Supports Windows® XP, Linux®, and Solaris™ 9/10 64-bit operating systems
- ◆ IPMI interface on the backplane
- ◆ Standard AT® peripherals include:
 - Real-time clock/CMOS RAM
 - 16C550 RS-232 serial port
 - USB 2.0 ports
- ◆ Dual-stage watchdog timer
- ◆ Push-button reset switch
- ◆ LEDs:
 - USER LED, dual color (green/yellow) accessible through an I/O port address
 - Hot Swap (Blue/Off)
 - Front Panel Ethernet Link (Green)
 - Front Panel Ethernet Traffic (Flashing Yellow)

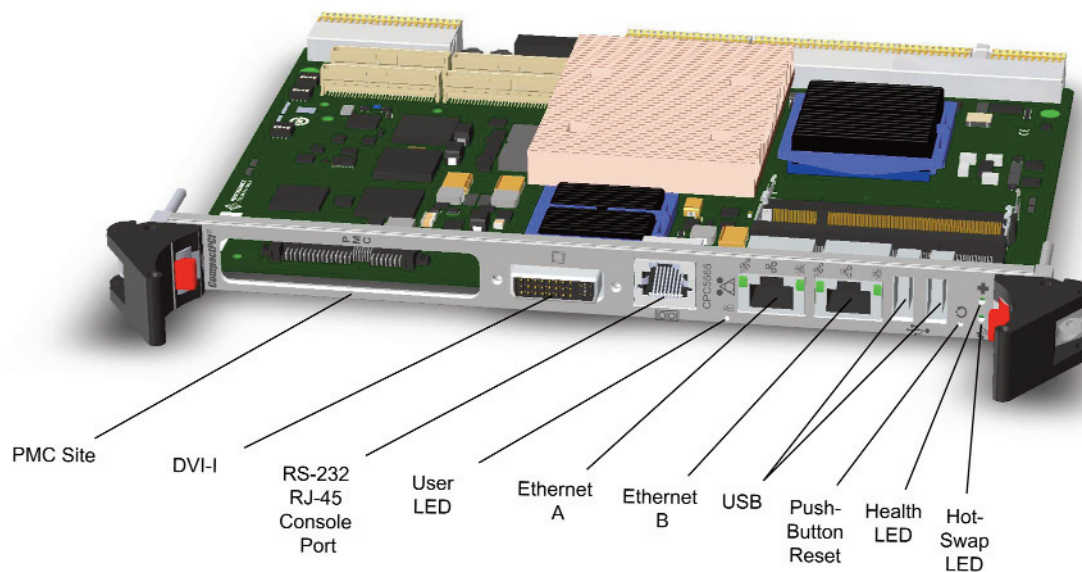

Figure 2-1: CPC5565 Front Panel

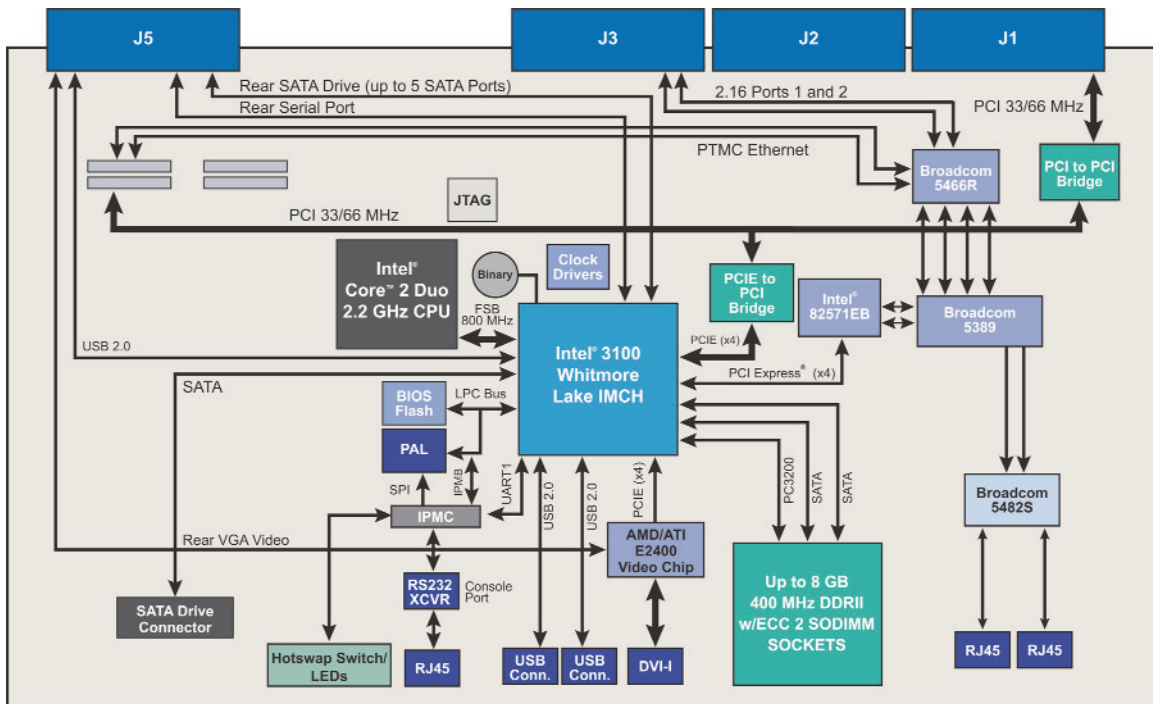

Figure 2-1: CPC5565 Front Panel

Processor

The CPC5565 incorporates the Intel® Core™2 Duo T7500 processor. The Intel Core 2 Duo T7500 processor is a 2.2 GHz, 35 W (TDP), high performance, low power, 64-bit processor that is compatible with 32-bit applications, enabling a single architecture across 32- and 64-bit environments.

The Intel Core 2 Duo implements dual-core technology that puts two mobile-optimized execution cores in a single processor that is designed to increase performance with significant power savings. Each core can complete up to four full instructions simultaneously using an efficient 14-stage pipeline. The two cores share 4 MB of L2 cache, offering more efficient data sharing, providing enhanced performance, responsiveness, and power savings. Each core utilizes enhanced Intel SpeedStep® technology on each core independently to coordinate power management state transitions and help save power. The 800 MHz front-side bus provides a high-speed interconnect with the Intel 3100 chipset.

Chipset

The CPC5565 incorporates the Intel® 3100 integrated chipset. The Intel 3100 chipset integrates the traditional north/south bridge functions as well as some SuperI/O and peripheral IC features into a single IC.

The Intel 3100 features:

- ◆ Processor/Host bus support:
 - 64-bit, 800 MHz front-side bus interface
 - Up to 36-bit host interface addressing support
 - Dynamic bus inversion to minimize power consumption on the data interface
 - In-Order Queue (IOQ) depth of 12, with debug support for the one-deep non-pipelined mode
 - Two outstanding DEFER cycles supported
 - AGTL+ driver technology with parallel termination

- ◆ Memory Interface
 - Support for two dual rank, registered SO-RDIMMs with ECC
 - Support for 15-bit address bus, 72-bit data bus (64-bit data plus 8-bit ECC)
 - Support for base DDR2 clock rate of 200 MHz: data interface double-pumped to 400 MT/s, data bandwidth of 3.2 GB/s
 - Support for 512 Mb, 1 Gb, and 2 Gb DRAM densities
 - Support for SO-RDDR2 DIMMs using x8 DRAM technology
 - Aggressive page-close policy with one-deep, look-ahead to minimize occurrence of page-miss accesses in favor of page-empty
 - Support for standard SEC-DED (72, 64) ECC
 - Support for automatic read retry on uncorrectable errors
 - Hardware ECC auto-initialization of all populated DRAM devices under software control. Includes pre-selected hardware pattern based memory test on programmable regions.

- ◆ PCI Express® interface features:
 - x8 interface capable of bifurcation into two logically independent x4 interfaces with full specification compliance at half the bandwidth capability
 - Low latency, high bandwidth
 - 32-bit CRC protection on all packets
 - CRC errors are recoverable by retransmission

- Supports 64-bit addressing
- Advance error detection and error transmission on destination bus
- Integrated bit-error generation and monitor function
- PCI-E v1.0 and v1.0a compliant
- Statistics for SNMP MIB II, Ethernet like MIB, and Ethernet MIB (802.3z, Clause 30)

CompactPCI® Bus Interface

The CPC5565 does not support a CompactPCI interface at backplane connector J4. The supported connectors provide access to the following signals:

- ◆ J1/J2: 3.3V/5V PCI 32 bit 33/66 MHz System Master (driving clocks)
- ◆ J3: Two PICMG® 2.16-compliant Ethernet ports
- ◆ J5: Five SATA interfaces. JTAG port for test/debug/manufacturing purposes

The CPC5565 is compliant with:

- ◆ PICMG 2.0 CompactPCI Core Specification
- ◆ PICMG 2.1 CompactPCI Hot Swap Specification
- ◆ PICMG 2.16 R1 CompactPCI packet-switched backplane (Ethernet) Specification
- ◆ PICMG 2.9 R1.0 CompactPCI System Management Specification

The CPC5565 supports hosting hot-swap peripherals in a powered system. The CPC5565 can also function in a standard (non-hot swap) CompactPCI system.

Intelligent Platform Management Controller

The CPC5565 includes an Intelligent Platform Management Controller (IPMC or BMC) based on the Atmel ATMEGA128L-8MU, which interfaces to the LPC bus, provides System Management Bus (SMB) interfaces, and is IPMI compliant. The IPMC subsystem monitors, controls, and performs remote diagnostics for many on- and off-board functions through IPMI (Intelligent Platform Management Interface) compliant system management bus interfaces.

The IPMC monitors system sensors for system management events, such as over temperature, out-of-range voltages, fan failures, etc., and logs any occurrences in its non-volatile System Event Log (SEL). You can view the SEL in the BIOS setup utility by selecting the IPMI 1.5 Configuration menu under the Advanced tab on the main menu. The IPMC also provides the interface to the sensors and SEL so system management software can poll and retrieve the present status of the system.

Note: The BIOS cannot currently display the IPMC SEL as there is no SEL implemented in the IPMC firmware at this time. Currently the BIOS maintains its own event log, but does not have access to any of the management sensors, so will only report BIOS errors. An IPMC SEL will be implemented in the future and at that time the BIOS will switch from a local event log to using the IMPC SEL. Currently there is no IMPI submenu in the Advanced menu.

Memory

The CPC5565 includes two 200-pin, Small Outline Registered Dual In-line Memory Module (SO-RDIMM) socket that can be populated with up to 8 GB DDR2-400 registered SDRAM. The BIOS automatically determines the SDRAM's size and speed.

Universal Serial Bus (USB)

The Universal Serial Bus (USB) provides a common interface to many peripherals such as keyboard, serial ports, and mouse ports. The CPC5565 supports booting from USB 2.0 devices, such as CD-ROM, DVD, or thumb drive.

The CPC5565 supports two standard USB 2.0 ports, available at the front panel. A third USB port is directed to the backplane via RPIO connector J5. The CPC5565's USB resides in the Intel® 3100 chipset.

AMD/ATI Radeon™ E2400 Video Processor

The CPC5565 incorporates the high performance AMD/ATI Radeon E2400 video processor, which delivers exceptional 2D, 3D, and multimedia graphics performance for embedded systems. It has 128 MB of internal GDDR3 Synchronous Graphics RAM (SGRAM) memory (two pieces of 16Mx32) integrated in the application-specific integrated circuit (ASIC) package.

The AMD/ATI Radeon E2400 video processor supports DirectX 10 with Shader Model 4.0, integrated Transition Minimized Differential Signaling (TMDS), and a Universal Video Decoder (UVD), which supports HD-DVD and Blu-ray Disc™ decode (H.264 or VC-1 formats).

The AMD/ATI Radeon E2400 video processor represents ATI's third-generation PCI Express® technology product and leverages a new graphics architecture. Based on 65 nm process technology, the AMD/ATI Radeon E2400 video processor delivers a 16-lane PCI Express bus interface and RoHS compliant ASIC.

Video Features

The AMD/ATI Radeon™ E2400 video processor provides one of the fastest and most advanced 2D, 3D, and multimedia graphics performances based on PCI Express® bus architecture. The E2400 supports PCI Express, DirectX 10 features, highly optimized Open Graphics Library® 2.0 support, and flexible memory configurations. The AMD/ATI Radeon E2400 video processor supports the following video features:

SMARTSHADER 4.0 - Advanced Shader Technology

- ◆ Provides complete hardware-accelerated support for the DirectX 10 programmable shader model, enabling more complex and realistic texture and lighting effects
- ◆ Significant improvement over first-generation shaders introduced in DirectX 8, with a more powerful and intuitive instruction set
- ◆ Offers full support for this feature in OpenGL 2.0 applications

SMOOTHVISION 2.0 - Flexible Anti-Aliasing and Anisotropic Filtering

- ◆ 2x/4x/8x full-scene anti-aliasing modes
- ◆ Adaptive algorithm with programmable sample patterns
- ◆ 2x/4x/8x/16x anisotropic filtering modes
- ◆ Adaptive algorithm with bi-linear (performance) and tri-linear (quality) options
- ◆ Temporal anti-aliasing

Avivo™ Display Support - Two Fully Functional Displays

- ◆ Traditional Cathode Ray Tube (CRT) monitors and DVI-D are supported
- ◆ Features dual channel DVI-D support
- ◆ 230 MHz Low-Voltage Differential Signaling (LVDS) transmitter supports Liquid Crystal Display (LCD) panels up to Quad eXtended Graphics Array (QXGA) (2048x1536) resolution
- ◆ Integrated TMDS transmitter that supports:
 - 1600x1200 resolution without reduced blank timings when matched with coherently clocked receivers
 - 1920x1440 resolution with reduced blank timings when matched with coherently clocked receivers
 - 1600x1200 resolution with reduced blank timings when matched with incoherently clocked receivers
- ◆ Supports standard single channel DVI-D, or Digital Flat Panel connections. Includes integrated conversion of 30 bpp data to either 24 bpp or 18 bpp, depending on attached panel type.
- ◆ High performance DAC speeds of 400 MHz

Video Acceleration

- ◆ The E2400 video processor allows integration of digital video features including advanced de-interlacing algorithms for high-quality video and integrated digital TV decode capability. Includes programmable, independent gamma control for the video overlay.
- ◆ Features in Detail and Motion Compensation (MC) support for the acceleration of MPEG encoding and decoding as well as Digital Video (DV) encoding and decoding.

Serial I/O

The CPC5565 provides one 16C550, PC-compatible serial port. COM1 is available at the front panel via 8-pin RJ-45 connector J7 and is also available to an RTM via RPIO connector J5. J7 is also routed to the IPMC console port for remote IPMC configuration. The console port mux is designed to be controlled from either the IPMC or the payload and to automatically default to the IPMC when the payload is powered down or powered up with un-configured programmable devices.

J7 is compatible with RS-232 signaling levels and 15KV ESD protection are provided by the interface. The port supports data transfers at speeds up to 115.2 Kb/sec. The baud rate is set if either console redirection or serial checkpoints is enabled. When the BIOS sets the baud rate for either of those features, the default is 9600 bps. If neither feature is enabled, the COM port is not configured by the BIOS.

The front panel RJ-45 serial port supports flow control. The rear panel serial port connection at J5 has the signalling reduced to simply Rx and Tx and does not support flow control signaling. The CPC5565's serial controller resides in the Intel 3100 chipset.

Ethernet Interface

The CPC5565 provides eight on-board 10/100/1000Base-T Ethernet channels through the onboard Broadcom BCM5389 GbE Port Switch. Ethernet channels can be directed through the BIOS setup utility, providing basic connectivity and functionality on power up and reset.

The eight on-board Ethernet channels are as follows:

- ◆ Front panel RJ-45 connectors J8 and J9 (Front Panel A and Front Panel B BIOS setup options). These connectors each have two LEDs to indicate the status of that channel.
- ◆ Two channels to midplane connector J3 (2.16 A and 2.16 B BIOS setup options)

- ◆ Two channels to optional on-board PMC site J11-J14 (PMC A and PMC B BIOS setup options). This site provides an interface for a dual channel gigabit Ethernet PMC mezzanine card. The site conforms to Option 7 of the PTMC Specification. The PMC card must have transformers on it to provide isolation from the CPC5565.
- ◆ Two channels to the host CPU via the 82571 dual NIC (ENET A and ENET B BIOS setup options). The on-board devices are grouped in pairs to support link aggregation to the switch to allow greater throughput and redundancy during normal operation.

SATA Interface

The CPC5565 includes an integrated Serial ATA (SATA) controller that routes six independent SATA interfaces, each of which is SATA 1.0 compliant:

- ◆ SATA drive mounted to the on-board SATA connector (build option)
- ◆ Five SATA ports routed to RPIO connector J5

Rear Transition Module (Optional)

The RTM4811, an advanced rear transition module, offers support for a SATA 2.5-in. hard or solid state drives, an analog VGA video interface, and USB 2.0 ports. The CPC5565 can boot from SATA storage on this RTM or through a SATA connector on the RTM faceplate.

The RTM4811 is designed to offer a wide range of storage options, including SD/HC and Mini-SD memory cards, SATA solid-state or hard drives as well as half-slim SATA devices. Any unused SATA connections can be routed to external SATA RAID arrays. When used in a non 2/16 application, this RTM can be used to route the 2 x Gb Ethernet connections to the rear panel of the RTM, However, this requires that the 2.5" drives be removed.

By using the RTM4811, the CPC5565 can be chained to a CPC5910 storage expansion module that contains two SATA 3.5-in. hard drive disks to make a local storage array with up to 4 TB of directly attached storage.

PTMC Interface (Build Option)

The CPC5565 is optionally also a PMC carrier card that supports the following specifications:

- ◆ Complies with PICMG® 2.15 R1.0 configuration 7 (PT7CC)
- ◆ Dual channel Ethernet links (MDI) compatible with PICMG 2.15 ECN 2.15-1.0-001 (Ethernet MDI Links on PTMC)
- ◆ Complies with IEEE1386.1 PCI Mezzanine Card (PMC)

Features

- ◆ Complies with VITA 39: PCI-X for PMC (133 MHz)
- ◆ Complies with PCI-E v1.0 and 1.0a (PCI Express)
- ◆ Support 3.3V VIO Cards Only

The PCI Telecom Mezzanine Card (PTMC) interface is compatible with the PICMG® 2.15 PT7CC Specification. The PTMC provides a way to add modules such as IPsec accelerators and network processors to increase baseboard functionality.

The CPC5565 PTMC site provides an industry-standard interface for a high performance, dual channel, gigabit Ethernet PMC mezzanine card. High performance is achieved by means of a 64-bit wide, 66 MHz interface that is capable of PCI or PCI-X signaling. Dual channel Ethernet links (MDI) are routed on PTMC interface connectors J11-J14 per PICMG 2.15 configurations 5 and 6. The Ethernet links can be routed to CPC5565 rear-panel gigabit Ethernet connector J3 for connection to the CompactPCI® backplane per PICMG 2.16.

NOTE: PCI-X is supported only when operating in Drone Mode.

The CPC5565 is backward compatible with all standard 32-bit and 64-bit PMC cards. However, these cards do not respect the PTENB# signal. We advise caution when installing a standard PMC card with P4 (rear I/O) signaling. Please check the pinout carefully: Connector J14 on the CPC5565 has pins 1 - 24 set to support two 1 Gigabit Ethernet channels. Make sure this definition does not interfere with the operation of the PMC card installed.

PMC modules interfacing to the CPC5565 must advertise their PTID (PCI Telecom Identifier) as "configuration 7" before they are enabled (PTENB# asserted). PMC modules supporting configurations 1, 2, 3, 4, 5, 6 will not have their PMC interface enabled by PTENB#. The mezzanine interface is at J11-J14 on the CPC5565.

Drone Mode

The CPC5565 can be set to operate in Drone mode when installed in a non-system slot in a CompactPCI chassis. In Drone mode it cannot drive the system clock or the CompactPCI bus. The CPC5565 can optionally be reset by the System Master when in a peripheral slot.

Real-Time Clock, CMOS RAM and Battery

The real-time clock performs timekeeping functions and includes 256 bytes of battery-backed CMOS RAM in two banks that are reserved for BIOS use. Timekeeping features include a

time-of-day clock and a multi-century calendar with alarm features and century rollover. The time, date, and CMOS values can be specified or returned to their defaults by using the BIOS setup program.

NOTE: The recommended method of accessing the date in systems with PT's Single Board Computers is indirectly from the real time clock via the BIOS. The BIOS on PT's Single Board Computers contains a century checking and maintenance feature. This feature checks the two least significant digits of the year stored in the real time clock during each BIOS request (INT 1Ah) to read the date and, if less than 80 (1980 is the first year supported by the PC), updates the century byte to 20. This feature enables operating systems and applications using the BIOS date/time services to reliably manipulate the year as a four-digit value.

Two rechargeable button-cell batteries located on the CPC5565 power the real-time clock and CMOS memory when the CPC5565 is not powered externally. The battery is intended for AC power fails only and has an estimated life of 60 days (with batteries fully charged). It recharges whenever standby power is present.

The CPC5565's real-time clock resides in the Intel 3100 chipset.

Reset

The CPC5565 provides the following reset types:

- ◆ Push-button reset
- ◆ IPMC generated reset (Payload Reset)
- ◆ Watchdog timer reset

Two-Stage Watchdog Timer

The watchdog timer optionally monitors system operation and is programmable for one of many different timeout periods (from 1 μ s to 1050s). It is a two-stage watchdog, meaning that it can be enabled to produce a SERIRQ, NMI or SMI interrupt during the first stage followed by a system reset for the second stage. Failure to strobe the watchdog timer within the programmed time period may result in an MI/SMI/SERIRQ, a system reset, or both. A register bit is set if the watchdog timer caused the reset event.

The CPC5565's two-stage watchdog timer resides in the Intel 3100 chipset.

LED Indicators

The LEDs located on the front panel are defined below. See Figure 2-1, "CPC5565 Front Panel," for LED locations.

- ◆ User LED

Bicolor LED controlled by system register settings:

- Green = user defined
- Yellow = user defined
- Off = user defined

- ◆ Front Panel Ethernet (RJ-45 Connector)

Each Ethernet connector on the front panel includes two LEDs:

- Ethernet Speed (Top)
 - ◆ Green = 100 Mb/s
 - ◆ Orange = 1000 Mb/s
 - ◆ Off = 10 Mb/s
- Ethernet Link (bottom)
 - ◆ Yellow = Link
 - ◆ Off = No Link

- ◆ Hot Swap

- Blue = safe to extract board
- Off = not safe to extract board
- Short Blink = payload is shutting down

- ◆ Status/Health

- Off = payload not powered
- Green = healthy (amber conditions not met)
- Amber = at least one threshold sensor has crossed a critical threshold, the payload is held in reset, power is not good (as detected by HW), the processor is reporting CPU Error, the processor is reporting Therm Trip, or the processor is in ACPI sleep state 5.

Rear-Panel I/O

The CPC5565 transitions the following I/O signals through CompactPCI® connector J5 to an optional Rear Transition Module:

- ◆ COM port
- ◆ Video
- ◆ Power and Ground
- ◆ USB
- ◆ SATA
- ◆ SMBus
- ◆ RPIO Present
- ◆ Eject
- ◆ JTAG

In addition, the CPC5565 transitions Gigabit Ethernet A and B through CompactPCI® connector J3.

Software

- ◆ BIOS
The PT Embedded BIOS (AMI core) is user-configurable to boot an operating system from one of the following locations:
 - USB mass storage device (hard drive, DVD-ROM or CD-ROM drive, flash drive, etc.)
 - Serial ATA (SATA) hard drives
 - Ethernet (PXE)
 - Any add-on cards/boards that support a BIOS boot specification option ROM
- ◆ Operating Systems Supported
Both 32- and 64-bit operating systems are supported:
 - WinXP and WinXP 64 have been installed and successfully run through Microsoft®'s Hardware Compatibility Test (pending).
 - Solaris™ 10 has been installed successfully (pending). Upon successful completion of Sun™ Hardware Compatibility Test Suite (HCTS), results will be posted to Sun's Web page <http://www.sun.com/bigadmin/hcl/overview.html>.
 - Red Hat® Enterprise Linux® AS 4 Update 3 (32 and 64 bit versions) has been installed successfully(pending).
 - NexusWare® Core has been installed and successfully run through PT's validation test suite (pending).

Configuration Options

The CPC5565 is designed for use with PT's complete line of Advanced Managed Platform™ products such as the AMP5086 and AMP5095 chassis. It allows system designers to build robust, highly-reliable solutions that combine state-of-the-art management, the highest performance power and cooling, and integrated switching. All of these solutions are compliant with the PICMG® CompactPCI® specification, which assures interoperability, broad vendor selection, and a range of choices to complement the CPC5565.

A clustered computing architecture built with the CPC5565 and standards-compliant Advanced Managed Platform can outperform proprietary blade server architectures from both computing density-per-rack and total-cost-of-ownership perspectives.

The RTM4811, an advanced rear transition module, offers support for SATA 2.5-in. hard disks or solid state drives, as well as an analog VGA video interface, and USB 2.0 ports. The CPC5565 can boot from the HDD/SSD on this RTM or through a SATA connector on the rear face plate. By using the RTM 4811, The CPC5565 can be chained to a CPC5910 storage expansion module that contains two 3.5-in. hard drive disks to make a local storage array with up to 4 TB of directly attached storage.

Thermal Design for Embedded Applications

The CPC5565 is designed to fit into the power and cooling capabilities of PT's Advanced Managed Platform solution, so customers can be assured that their applications will meet stringent requirements that include NEBS, UL, and ETSI. It is also designed from the ground up to be RoHS-compliant for systems that require toxic materials elimination. By employing advanced techniques that include the use of the onboard IPMC microcontroller to control CPU clock speed, PT has designed the CPC5565 to automatically adjust to the most demanding environmental conditions.

Product Number	Description
PT-CPC5565-12389	Intel® Core™2 Duo 2.2 GHz 64-Bit SBC, 2GB, no HDD, PMC
PT-CPC5565-12390	Intel Core 2 Duo 2.2 GHz 64-Bit SBC, 2GB, 250 GB 24x7 HDD, No PMC
PT-CPC5565-12391	Intel Core 2 Duo 2.2 GHz 64-Bit SBC, 4GB, no HDD, PMC
PT-CPC5565-12392	Intel Core 2 Duo 2.2 GHz 64-Bit SBC, 4GB, 250 GB 24x7 HDD, No PMC
PT-CPC5565-12393	Intel Core 2 Duo 2.2 GHz 64-Bit SBC, 8GB, no HDD, PMC
PT-CPC5565-12394	Intel Core 2 Duo 2.2 GHz 64-Bit SBC, 8GB, 250 GB 24x7 HDD, No PMC
PT-CPC5565-12425	Intel Core 2 Duo 2.2 GHz 64-Bit SBC, 2GB, 160 GB SSD, No PMC
PT-CPC5565-12426	Intel Core 2 Duo 2.2 GHz 64-Bit SBC, 4GB, 160 GB SSD, No PMC
PT-CPC5565-12427	Intel Core 2 Duo 2.2 GHz 64-Bit SBC, 8GB, 160 GB SSD, No PMC
PT-CPC5910	SATA Storage Expansion Module with two hot-swappable SATA drives. Requires RTM4810 rear transition module with SATA chain cable.
PT-RTM4811-12461	Rear Transition Module w/SATA interfaces, no HDD
PT-RTM4811-12460	Rear Transition Module w/SATA 24/7 HDD
PT-RTM4811-12459	Rear Transition Module w/SATA MLC Solid State Drive
PT-RTM4811-12458	Rear Transition Module w/2 Rear Panel Gb Ethernet Connections, no HDD/SSD for use in a non-2.16 chassis only
PT-ACC102-12479	1 Meter mini-SAS to mini-SAS cable

Technical Specifications

Processor

- ◆ Intel® Core™2 dual-core architecture:
 - Independent L1 cache structures per core
 - Shared L2 cache (4 MB)
 - 64-bit processor
- ◆ Compatible with existing 32-bit code base
- ◆ Enhanced Intel SpeedStep® technology for more efficient power management

Video

- ◆ AMD/ATI Radeon™ E2400 Video Processor
 - Internal 128 MB GDDR3 Memory
 - High-performance 2D, 3D, and multimedia graphics
 - QXGA resolution up to 2048 x 1536
 - HDMI output for 480p, 720p, and 1080i
 - 32 bits per pixel
 - DirectX 10 and OpenGL 2.0 support
 - Video acceleration
 - ◆ Advanced de-interlacing algorithms
 - ◆ Programmable, independent gamma control for video overlay
 - SMARTSHADER™ 4.0
 - SMOOTHVISION™ 2.0
 - Dual-display mode
 - Integrated HD audio codec supports PCM and Dolby® Digital 5.1 Audio Formats

Memory

- ◆ Low latency, high bandwidth
- ◆ 64-bit DDR2 PC2-3200
- ◆ 200-pin SO-RDIMM
- ◆ Supports up to 8 GB DRAM
- ◆ ECC checking with double-bit detect and singlebit correct

Physical Interfaces

- ◆ Onboard Managed Switch
 - 1 Gb routed to:
 - ◆ Host CPU, two ports
 - ◆ PMC slot, two ports
 - ◆ PICMG® 2.16 backplane, two ports
 - ◆ Front panel, two ports
- ◆ PMC slot
- ◆ Support for up to 6 SATA devices
 - 1 to the onboard SATA HDD
 - 1 to J5 of the RTM
 - Up to 4 external SATA ports on the RTM
- ◆ Three USB 2.0 ports
 - Two front and one rear

- ◆ Onboard video
 - DVI-I connector for digital and/or analog video
 - Rear VGA connector
- ◆ Serial port
 - Front/rear
- ◆ User-defined LEDs

Dimensions

- ◆ Single width CompactPCI® form factor, 6U x 4HP (233 mm x 160 mm)

Switch Management

- ◆ CLI via RS-232 and in-band Ethernet ports
- ◆ Telnet
- ◆ SNMP v1, v2c, v3 – RFC 1157
- ◆ MIBs
 - MIBII – RFC 1213, MIBII bridge – RFC 1493
 - IEEE 802.1q MIB – RFC 2674
 - PT enterprise MIB

Specification Compliance

- ◆ PICMG 2.16 R1 CompactPCI packet-switched backplane
- ◆ PICMG 2.9 R1.0 CompactPCI system management specification/IPMI (intelligent platform management interface) version 1.5
- ◆ IEEE Std. 802.3 – 2000 edition CSMA/CD access method and physical layer specification
- ◆ USB 2.0, high speed

Power

- ◆ 66 W maximum with V(I/O) set to 3.3V
 - Multiple low power states
 - System Management Mode (SMM)
 - ACPI Compliant

Environmental

- ◆ Operating: 0 to 55°C (32 to 131°F)
- ◆ Non-operating: -20 to 80°C (-4 to 176°F)
- ◆ Humidity: 5 to 90% RH non-condensing

Agency Certifications (Pending)

- ◆ FCC Class A
- ◆ CE
- ◆ UL 60950
- ◆ EN 60950
- ◆ ETSI EN 300 386
- ◆ Designed to meet the requirements of NEBS Level 3

MTBF

- ◆ TBD

Company Overview

PT is a global supplier of advanced network communications solutions to carrier, government, and OEM markets. The company's award-winning products include IP-centric network elements and applications designed for high availability, scalability, and long life cycle deployments. Over the years, PT has developed an impressive portfolio of communications offerings, through organic expansion as well as acquisitions.

Fully Integrated Product Portfolios

All products from PT reflect a significant body of real-world network experience and offer carriers, equipment manufacturers, and integrators carefully architected solution sets for communications network deployments.

The company's entire line of offerings is anchored by IPnexus[®], PT's own IP-native, highly integrated platforms and element management systems. OEMs and application developers, including PT itself, leverage the robust carrier grade Linux[®] development environment and rich suite of communications protocols (PT's NexusWare[®]) of IPnexus Application-Ready Systems as a cornerstone component of their end product value proposition.

SEGway[™] Signaling Solutions, PT's premier suite of IP-centric STPs, gateways, edges, and network applications, permits service providers to cost-effectively deliver revenue generating features in next-generation networks. SEGway solutions have been deployed in numerous world-class carrier networks around the globe because of their high density and unparalleled price-to-performance ratio. This, together with SEGway's flexibility in edge-to-core deployments, small footprint, and ease of use, has earned the portfolio its reputation as "Simply Smarter Signaling[®]."

PT's Xpress[™], the company's newest line, combines a powerful, customizable software application with a robust, hardware platform that is specifically engineered to deliver SIP-based solutions such as calling card and Pre-paid for next-generation networks. Based on a pure IP implementation, new service offerings can be quickly developed and deployed network-wide on IMS-enabled, converged TDM/IP and VoIP networks. The Xpress family of NGN solutions provides dynamic opportunities to build-out next-generation network solutions and value-added services

Single Vendor Solution for Products and Services

Customers around the globe are turning to PT as a single source provider of high value proposition network communications solutions coupled with world-class support and maintenance programs.

Over 29 Years of Innovation and Industry Experience

PT has proven success in defining new levels of performance and adapting its products and services to a constantly changing marketplace. This expertise has enabled the company to remain a leader in its industry markets.

Today, backed by an innovative team of experts, PT offers a rich value proposition that enable its customers to meet their most pressing business and technology challenges, and thereby compete more successfully.

PT is headquartered in Rochester, NY and maintains sales and engineering offices around the world.

For more information contact PT at:

Phone: +1.585.256.0200

Web: www.pt.com

E-Mail: sales@pt.com

IPnexus, NexusWare, Point Code Emulation, PT, SEGway, Simply Smarter Signaling and Xpress are trademarks or registered trademarks of Performance Technologies, Inc.

The names of other companies, products, or services may be the trademarks, registered trademarks, or service marks of their respective owners in the United States and/or other countries.