



Highlights

- >> Single-Slot 6U Intelligent Access Controller

- >> Eight Fully Channelized T1/E1/J1 Spans

- >> Optional Support Software:
 - NexusWare® CGL OS and Development Environment
 - NexusWare® C7 SS7 MTP-2 Installable Software Package
 - NexusWare® WAN Protocol Software:
 - Radar Receiver
 - TADIL-B
 - HDLC
 - X.25
 - Frame Relay

- >> Add DSP/CPU Processing via PTMC Sites

- >> 800 MHz PowerPC® with L1/L2 Cache

- >> Built-In TCP Acceleration Hardware

- >> Onboard Eight-Port Gigabit Switch

- >> PICMG® 2.16 or Standard PCI™ Bus Operation

The CPC308 is a network-optimized access controller that is ideally suited for both PSTN and IP telephony applications. The ability to add scalable DSP/CPU processing via the PCI Telecom Mezzanine Card (PTMC) sites combined with onboard TDM/IP switches makes the CPC308 an ideal platform for developers of telephony systems.

Featuring eight fully programmable T1/E1/J1 interfaces, the CPC308 offers a comprehensive design that is ideal for supporting voice, data, signaling, and monitoring applications, all via one architecture.

The CPC308 is optimized to handle voice circuits for protocol processing or for transfers between the H.110 bus, PCI bus, Ethernet, or onboard PTMC sites. The two PTMC sites provide the ability to connect two single or one dual PTMC module. The PTMC interfaces support 32-bit PCI, H.110 style TDM, RMII, and 10/100/1000 Ethernet. Application examples include: wireless infrastructure equipment, media and signaling gateways, IP media equipment, telecom switching and routing equipment, and SS7 network elements. The CPC308 offers true TDM/IP bridge capability in addition to supporting full H.110 and PICMG® 2.16 backplanes, framers for external connections, and full gigabit IP interconnect between major components.

Hardware Features

The CPC308 utilizes a 800 MHz PowerPC® processor with L1/L2 cache and built-in TCP Acceleration Hardware (TAH). By using the onboard TDM edge processor, the CPC308 can support up to 256 HDLC channels. The CPC308 fully complies with the latest PICMG hot-swap specification, and its fully passive RTMs also improve reliability. By incorporating the H.110 interface device, the CPC308 can send/receive any of its possible time slots to the J4 connector.

NexusWare® Software Support

The NexusWare® software suite offers a CGL Registered and POSIX-compliant Linux® operating system and development environment. In addition, the suite includes an extensive list of installable protocols that can be leveraged to build robust solutions, such as media gateways, lawful intercept platforms, SS7 monitoring equipment for line usage/billing applications, radar gateways, and converged serial gateways.

CPC308

Eight-Port T1/E1/J1 TDM/IP Edge Processor

The NexusWare family of products includes:

NexusWare Core: At the very center of the NexusWare suite of software is NexusWare Core, which provides a comprehensive, highly integrated, Linux development, integration and management environment. It is intended for system engineers who use Performance Technologies' embedded products to build packet-based systems, including next-generation wireless and IP-based systems.

NexusWare C7: Comprehensive SS7 MTP-2 installable software package for NexusWare Core. NexusWare C7 provides a foundation for building SS7 applications, including next-generation wireless and IP telephony systems, to equipment manufacturers and application developers who use Performance Technologies' embedded products.

NexusWare WAN: Extensive offering of protocol packages including, but not limited to, HDLC, X.25, Frame Relay, and Radar Receiver. When combined with Performance Technologies' embedded products, these will enhance the ability of developers to create flexible and efficient radar gateways, converged serial gateways, and front-end I/O systems.

The WAN software products are offered as installable software packages for NexusWare Core or as turnkey packages for those developers interested in the protocol package by itself. Whether the installable or turnkey solution is chosen, developers will be provided with a well-documented and powerful API to assist in the development process.

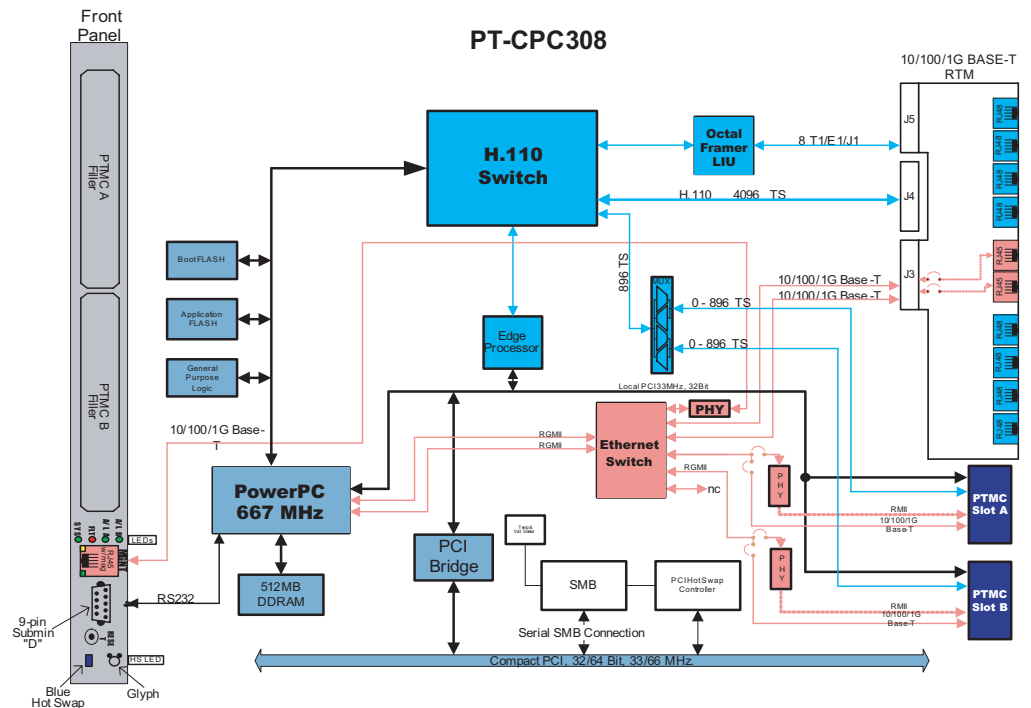

CPC308 - Block Diagram

CPC308

Technical Specifications



Interface

- Eight T1 ports @ 1.544 Mbps
- Eight E1 ports @ 2.048 Mbps
- Eight J1 ports @ 1.544 Mbps
- Three 10/100/1000 Ethernet ports

Processor

- 800 MHz PowerPC processor
- 64-bit data and 32-bit address bus
- Built-in TAH capability

Framing Standards

- AMI/B8ZS
- D-4, ESF
- DS-1, PRI

Memory

- 512 MB dedicated DDR SDRAM
- 32 KB/32 KB instruction/data L1 cache
- 256 KB L2 cache and/or high speed packet/code store
- 128 MB flash PROM

Specification Compliance

- ECTF H.110 hardware compatibility specification: CT Bus revision 1.0
- I2C Bus specification, version 2.1
- IEEE P1386 2.4a March 21, 2001 common mezzanine card family
- IEEE P1386.1 Draft 2.4 Jan 12, 2001 PCI mezzanine cards, PMC
- IEEE Std. 802.3 - 2000 edition CSMA/CD access method and physical layer specification
- IPMI intelligent platform management specification, version 1.5
- JEDEC JESD79C Double Data Rate (DDR) SDRAM specification
- PCI Local Bus specification revision 2.2
- PICMG 2.0 R 3.0 CompactPCI® core specification
- PICMG 2.1 R2.0 hot-swap specification
- PICMG 2.9 R1.0 CompactPCI system management specification
- PICMG 2.15 R1.0: ECN 2.15 PCI telecom mezzanine/carrier card specification
- PICMG 2.16 R1.0 CompactPCI packet-switched backplane
- VITA 32-199x processor PMC standard draft 0.41-compatible

Physical Interface

- T1/E1/J1: Eight T1/E1/J1 port connections via eight RJ48C connectors on the RTM
- Ethernet: Two RJ-45 connectors on RTM, one RJ-45 on front panel, two PICMG 2.16 fabric connections
- Monitor: One nine-pin subminiature on front panel

Protocol Support

- MTP2 Link Layer
- Transparent (Voice Stream)
- HDLC
 - LAPD (Q.921), LAPB, LAPF
- X.25
- Frame Relay

Power

- 22.9 W maximum
 - 3.3 V supply, 11.9 W maximum
 - 5 V supply, 10 W maximum
 - +12 V supply, 60 mW maximum
 - -12 V supply, 40 mW maximum

Dimensions

- 6U Eurocard form factor

Temperature

- Operating: 0 to 50°C (32 to 122°F)
- Non-operating: -20 to 80°C (-4 to 176°F)

Agency Certifications

- FCC Class A
- CE
- UL 60950/EN 60950
- ETSI EN 300 386
- Designed to meet the requirements of NEBS Level 3

Ordering Information

>> **PT-CPC308-11975**
Eight-port T1/E1/J1 Advanced Subsystem

>> **PT-RTM308-11744**
Eight-port RTM (Eight RJ48C Connectors)

Software Options

>> **PT-NXSWARE-11359**
NexusWare Linux Software

>> **PT-HDLCKIT-11490**
HDLC Connectivity Kit

>> **PT-FRAMKIT-11661**
Frame Relay Development Kit

>> **PT-X25KIT-11612**
X.25 Development Kit

>> **PT-ASYNKIT-11702**
Async Development Kit

>> This product is available with a variety of software options. For more information, contact sales@pt.com.



Corporate Headquarters:
Performance Technologies
205 Indigo Creek Drive
Rochester, NY 14626 USA

Tel: 585.256.0200
Fax: 585.256.0791
E-mail: sales@pt.com

European Headquarters:
Performance Technologies UK Ltd.
Challenge House
Sherwood Drive, Bletchley
Milton Keynes, MK3 6DP UK

Tel: +44 (0) 1908 646000
Fax: +44 (0) 1908 646001
E-mail: sales@pt.com

www.pt.com