



Highlights

- >> PICMG® 2.16 or Standard PCI Bus Operation

- >> 800 MHz PowerPC® with L1/L2 Cache

- >> Two Intelligent PTMC Sites

- >> Built-in TCP Acceleration Hardware

- >> Onboard Gb Ethernet Switch

- >> Onboard H.110 Switch

- >> Optional Support Software:
 - NexusWare® CGL OS and development environment
 - NexusWare C7 SS7 MTP-2 installable software package
 - NexusWare WAN installable software packages:
 - HDLC
 - x.25
 - Frame Relay

The CPC300 is an advanced PTMC carrier blade that allows systems integrators to create a custom blade by populating it with PTMC modules that meet specific application requirements. Providing two PTMC sites that comply with the PICMG® 2.15 standard, the CPC300 can be used with the wide array of PTMC modules available today, including telecom I/O cards, DSP cards, and packet processing modules.

The ability to add scalable DSP/CPU processing via PTMC sites, combined with onboard TDM/IP/H.110 switches and 800 MHz PowerPC®, makes the CPC300 an ideal choice for developers looking for an intelligent platform to provide a flexible, PTMC-based configuration.

The PTMC interfaces support 32-bit PCI, H.110-style TDM, RMII, and 10/100/1000 Ethernet. Developers can use this intelligent platform with best-of-class PTMC modules to yield media and signaling gateways, IP media equipment, telecom switching/routing equipment, and SS7 network elements. The CPC300 offers true TDM/IP bridge capability and supports full throughput of H.110 and PICMG 2.16 backplanes. Using the wire-speed Gb Ethernet switch, it also offers full duplex interconnects between major onboard and chassis components.

Hardware Features

The CPC300 utilizes an 800 MHz PowerPC processor with L1/L2 cache and built-in TCP acceleration hardware (TAH). By using the onboard TDM edge processor, the CPC300 can support up to 256 HDLC channels. The CPC300 fully complies with the latest PICMG hot-swap specification, and its fully passive RTMs also improve reliability. By incorporating the H.110 interface device, the CPC300 can connect up to 1,792 timeslots between the H.110 bus and the PTMC sites.

NexusWare® Software Support

The NexusWare® software suite offers a CGL-registered and POSIX-compliant Linux®-based operating system and development environment. In addition, the suite includes an extensive list of installable protocols that can be leveraged to build robust solutions, such as media gateways, lawful intercept platforms, SS7 monitoring equipment for line usage/billing applications, radar gateways, and converged serial gateways. Software engineers can choose any of these environments to develop in and simply recompile their code for the target, when ready.

CPC300

Advanced PTMC Carrier Blade

The NexusWare family of products includes:

NexusWare Core: At the very center of the NexusWare suite of software is NexusWare Core, which provides a comprehensive, highly integrated, Linux-based development, integration and management environment. It is intended for system engineers who use Performance Technologies' embedded products to build packet-based systems, including next-generation wireless and IP-based systems.

NexusWare C7: Comprehensive SS7 MTP-2 installable software package for NexusWare Core. NexusWare C7 provides a foundation for building SS7 applications, including next-generation wireless and IP telephony systems, to equipment manufacturers and application developers who use Performance Technologies' embedded products.

NexusWare WAN: Extensive offering of protocol packages including, but not limited to, HDLC, X.25, Frame Relay, and Radar Receiver. When combined with Performance Technologies' embedded products, these will enhance the ability of developers to create flexible and efficient radar gateways, converged serial gateways, and front-end I/O systems.

The WAN software products are offered as installable software packages for NexusWare Core or as turn-key packages for those developers interested in the protocol package by itself. Whether the installable or turn-key solution is chosen, developers will be provided with a well-documented and powerful API to assist in the development process.

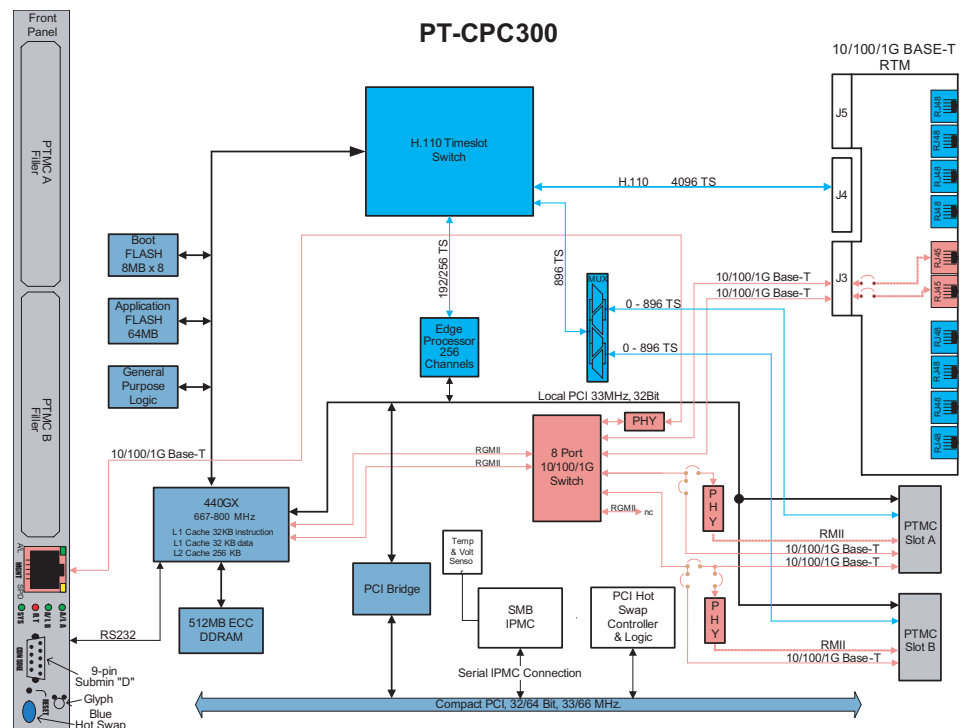

CPC300 - Block Diagram

CPC300

Technical Specifications



PTMC Sites

- PICMG 2.15 Configuration 2-compliant
- PICMG 2.15 Configuration 3-compliant for J3 connector
- PICMG 2.15 Configuration 5-compliant for J4 connector

Processor

- 800 MHz PowerPC processor
- 64-bit data bus and 32-bit address bus
- Built-in TAH capability

Memory

- 512 MB dedicated DDR SDRAM
- 32 KB/32 KB instruction/data L1 cache
- 256 KB L2 cache and/or high-speed packet/code store
- 128 MB flash PROM

Physical Interface

- Gb Ethernet: Two RJ-45 connectors on RTM, one RJ-45 on front panel, two PICMG 2.16 fabric connections
- Monitor (CLI): One 9-pin subminiature on front panel

Protocol Support

- MTP2 Link Layer
- Transparent (voice stream)
- HDLC
 - LAPD (Q.921), LAPB, LAPF
- X.25
- Frame Relay

Power

- 22.9 W maximum
 - 3.3 V supply 11.9 W maximum
 - 5 V supply 10 W maximum
 - +12 V supply 60 mW maximum
 - -12 V supply 40 mW maximum

Specification Compliance

- ECTF H.110 hardware compatibility specification: CT Bus revision 1.0
- I2C Bus specification, version 2.1
- IEEE P1386 2.4a March 21, 2001 common mezzanine card family
- IEEE P1386.1 Draft 2.4 Jan 12, 2001 PCI mezzanine cards, PMC
- IEEE Std. 802.3 - 2000 edition CSMA/CD access method and physical layer specification
- IPMI intelligent platform management specification, version 1.5
- JEDEC JESD79C Double Data Rate (DDR) SDRAM specification
- PCI Local Bus specification revision 2.2
- PICMG 2.0 R 3.0 CompactPCI® core specification
- PICMG 2.1 R2.0 hot-swap specification
- PICMG 2.9 R1.0 CompactPCI system management specification
- PICMG 2.15 R1.0 ECN 2.15 PCI telecom mezzanine/carrier card specification
- PICMG 2.16 R1.0 CompactPCI packet-switched backplane
- VITA 32-199x processor PMC standard draft 0.41-compatible

Dimensions

- 6U Eurocard form factor

Temperature

- Operating: 0 to 50°C (32 to 122°F)
- Non-operating: -20 to 80°C (-4 to 176°F)

Agency Certifications (pending)

- FCC Class A
- CE
- UL 60950 / EN 60950
- ETSI EN 300 386
- Designed to meet the requirements of NEBS Level 3

Ordering Information

- >> **PT-CPC300-11976**
Advanced PTMC carrier blade
- >> **PT-RTM308-11966**
Rear transition module (required for non-PICMG 2.16 applications)



Contact Information

Performance Technologies
205 Indigo Creek Drive
Rochester, NY 14626

Tel: 585.256.0200
Fax: 585.256.0791
E-mail: sales@pt.com

www.pt.com