



### Highlights

- >> Multipurpose Intelligent WAN Communications Module for AdvancedTCA<sup>®</sup> and MicroTCA<sup>®</sup> Systems
- >> Mid-Size Single AMC Module
- >> Full Compliance with AMC Specifications
- >> Four High-speed Channels Capable of Sustaining 2 Mbps per Port
- >> Freescale<sup>™</sup> MPC8270 PowerQUICC<sup>®</sup> II Processor
- >> 128 MB Dedicated Processor SDRAM Memory
  - Handles Extensive Onboard Traffic and Protocol Requirements
- >> 32 MB Application Flash
- >> NexusWare<sup>®</sup> WAN Protocol Software:
  - Radar Receiver
  - TADIL-B
  - HDLC
  - X.25
  - Frame Relay
  - ASYNC
- >> NexusWare<sup>®</sup> CGL OS and Development Environment
- >> Broad Operating System Support Includes Solaris<sup>™</sup>, Windows<sup>®</sup>, and Linux<sup>®</sup>

The use of AdvancedTCA<sup>®</sup> and MicroTCA<sup>®</sup> systems for the aerospace and defense markets, as well as for telecom OEMs, will require high-density, highly advanced I/O solutions for use in these new environments. As a long-time contributor to industry standards and emerging technologies, Performance Technologies provides a combination of powerful hardware and advanced software that enables its customers to fully leverage AdvancedTCA and MicroTCA capabilities for the creation of high-density, high-performance solutions.

The AMC335 Intelligent Synchronous WAN Communications module provides four high-performance synchronous/serial channels for WAN connectivity. This module is ideally suited for use in creating flexible and efficient radar gateways, radar recorders, protocol convertors, serial gateways, and front-end I/O elements as well as many other high-speed communications devices that require RS232, RS422 (RS449/EIA530), and V.35 connectivity. The AMC335 is part of Performance Technologies' industry-leading family of AMC solutions that include compute, storage, and video supported by powerful enabling software for embedded applications.

### Hardware Features

The AMC335 is designed as a fully programmable communications subsystem that is capable of sustaining high data rates for a variety of protocols that are used in synchronous data communications. The architecture of the AMC335 capitalizes on the intelligence of the Freescale<sup>™</sup> MPC8270 Quad Integrated Communications Controller (PowerQUICC<sup>®</sup> II), which enable it to act as a specialized communications controller.

The AMC335 enhances overall system performance by using its onboard intelligence and 128 MB SDRAM array. The AMC335 is capable of handling much of the low-level communications that typically burden the host processor, and relegates most of the serial I/O communication-related processing to the AMC335. In addition, the SDRAM eliminates the start-up delays associated with application download wait times by enabling the code to be executed directly onboard. The AMC335 allows the use of PCI Express<sup>®</sup> or Ethernet for interconnecting to other subsystems that will be used in the AdvancedTCA or MicroTCA-based solution.

Three models of the AMC335 are available to support RS232, RS422, and V.35 standards. All four ports of connectivity are accessible through the high-density, dual-stacked VHDCI connector on the front panel of the AMC335. Optional hydra cables allow the choice of RS232, RS449, EIA530, or V.35 connections depending on the model of AMC335.



# AMC335

## Intelligent Synchronous WAN Communications Module

### Ordering Information

- >> **PT-AMC335-12258**  
Four-Port RS422 AMC Module
- >> **PT-AMC335-12289**  
Four-Port RS232 AMC Module
- >> **PT-AMC335-12287**  
Four-Port V.35 AMC Module

### Software Options

- >> Performance Technologies' NexusWare® suite of software provides a comprehensive Carrier Grade Linux® (CGL) OS and development environment as well as middleware and protocol communications software.

For more information visit [go.pt.com/software](http://go.pt.com/software) or call your local representative.

### NexusWare® Software Support

The NexusWare® software suite offers a CGL Registered and POSIX-compliant Linux® OS and development environment. In addition, the suite includes an extensive list of installable protocols that can be leveraged to build robust solutions, such as media gateways, lawful intercept platforms, SS7 monitoring equipment for line usage/billing applications, radar gateways, and converged serial gateways.

The NexusWare family of products supported on the AMC335 includes:

**NexusWare Core:** At the very center of the NexusWare suite of software is NexusWare Core, which provides a comprehensive, highly integrated, Linux OS development, integration, and management environment. It is intended for system engineers who use Performance Technologies' embedded products to build packet-based systems, including next-generation wireless and IP-based systems.

**NexusWare WAN:** Extensive offering of protocol packages that include, but are not limited to, HDLC, X.25, Frame Relay, and Radar Receiver. When combined with Performance Technologies' embedded products, these will enhance the ability to create flexible and efficient product platforms such as radar gateways, converged serial gateways, and front-end I/O systems.

The WAN software products are offered as installable software packages for NexusWare Core or as turnkey packages for those developers interested in the protocol package by itself. Whether the installable or the turnkey solution is chosen, developers will be provided with a well-documented and powerful API to assist in the development process.

# AMC335

## Technical Specifications

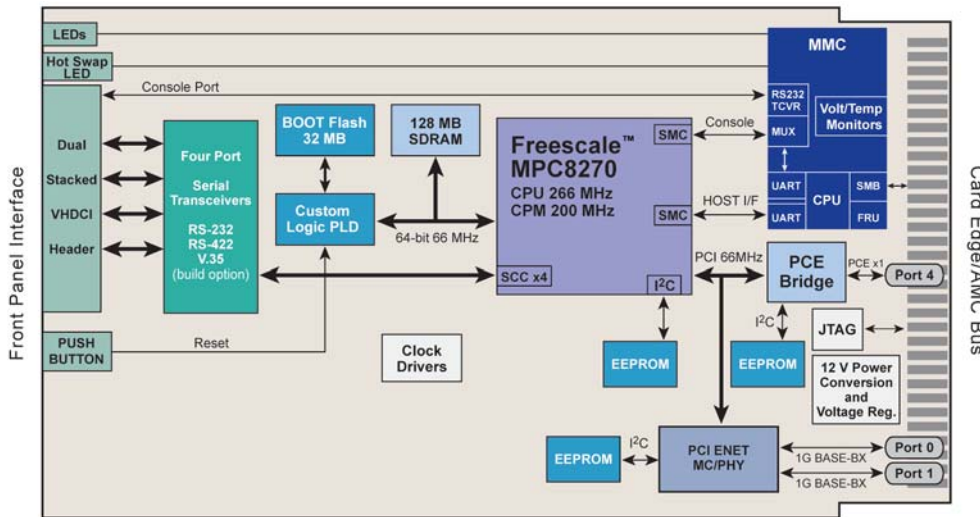

AMC335 – Mid-Size, Single WAN Communications Module

### Performance

- Four ports at 2 Mbps bi-directional
- Simultaneously sustained 8 Mbps maximum line speed

### Processor

- 266 MHz Freescale™ MPC8270 Freescale PowerQUICC II

### Memory

- 128 MB SDRAM
- 32 MB Application Flash

### Protocol Support

- Radar Receiver/SBSI, HDLC, Frame Relay, LAPD, X.25, ASYNC

### Agency Certifications (Pending)

- FCC Class A
- CE (EN55022 and EN55024)
- ETSI EN 300 386 immunity
- UL60950
- EN 60950-1

### Physical Interface

- RS449
- EIA530
- RS232
- V.35

### AdvancedMC™ Connector Ports

- AMC.0 Compliant
- Port 0: 1 Gb Ethernet Channel 1 (AMC.2)
- Port 1: 1 Gb Ethernet Channel 2 (AMC.2)
- Port 4: x1 PCI Express (AMC.1)

### MTBF

- 383,371 hours per Bellcore SR-332 Issue 2

### Power (Estimated)

- Payload Power: 12 W
- Management Power: 3.3 V
- Typical: 10.2 W
- Maximum: 12.6 W

### Mechanical

- Mid-size, single AMC.0 form factor
- Dimensions: 180.6 mm x 73.5 mm (7.1 in. x 2.9 in.)
- Weight: 0.11 kg (0.25 lb)

### Environmental

- Operating: 0 to 60°C (32 to 140°F)
- Non-operating: -20 to 80°C (-4 to 176°F)
- Humidity: 5 to 90% RH non-condensing

### Front Panel Interfaces

- Dual VHDCI connector carrying four independent Serial I/O ports
- LEDs
  - In Service (IS)
  - Out of Service (OOS)
  - Application (APP)
  - Hot Swap
- Reset Switch
- Insert/Extraction Handle

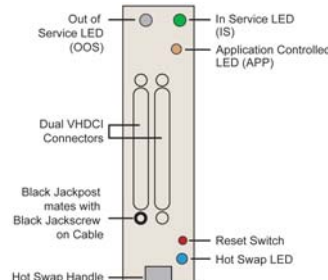

## Ordering Information

### Cable Options

- >> **PT-ACC335-12205**  
Four-position, 6 ft Hydra Cable without Console, RS449
- >> **PT-ACC335-12203**  
Four-position, 6 ft Hydra Cable with Console, RS449
- >> **PT-ACC335-12233**  
Four-position, 6 ft Hydra Cable with Console, RS232
- >> **PT-ACC335-12234**  
Four-position, 6 ft Hydra Cable without Console, RS232

- >> **PT-ACC335-12256**  
Four-position, 6 ft Hydra Cable with Console, EIA530

- >> **PT-ACC335-12257**  
Four-position, 6 ft Hydra Cable without Console, EIA530

- >> **PT-ACC335-12290**  
Four-position, 6 ft Hydra Cable with Console, V.35

- >> **PT-ACC335-12291**  
Four-position, 6 ft Hydra Cable without Console, V.35



**Corporate Headquarters:**  
Performance Technologies  
205 Indigo Creek Drive  
Rochester, NY 14626 USA

Tel: 585.256.0200  
Fax: 585.256.0791  
E-mail: sales@pt.com

**European Headquarters:**  
Performance Technologies UK Ltd.  
Challenge House  
Sherwood Drive, Bletchley  
Milton Keynes, MK3 6DP UK

Tel: +44 (0) 1908 646000  
Fax: +44 (0) 1908 646001  
E-mail: sales@pt.com

[www.pt.com](http://www.pt.com)